



The Manhattes Group LLC

263 Bowery
Between Houston and Stanton

Prime Bowery Commercial Space for Lease

Three Floors of Retail Space Available in a 7-Story Residential Building

- * Can Lease entire space or floors separately
- * Brand New Construction
- * Elevator Building
- * Space is column free
- * Venting possible — All Uses Considered



Alan Shmaruk x11 Andrew Braver x13

The Manhattes Group LLC 54 Thompson Street 2nd Floor New York, NY 10012

212-334-4666



The Manhattes Group LLC

263 Bowery
Between Houston and Stanton

Location:	Bowery between Houston and Stanton
Space:	Lower Level – 1,230 sf Ground Floor – 2,144 sf 2nd Floor – 2,450 sf 3rd Floor – 2,023 sf + outdoor space
Frontage:	Ground Floor – 20 feet 2nd & 3rd Floors – 25 feet
Rent:	Upon Request
Term:	Negotiable
Possession:	Upon completion of lease agreement
Completion:	End of 1st Quarter 2010
Neighbors:	Whole Foods, Pulino's (Keith McNally's new restaurant), The New Museum of Contemporary Art and D.B.G.B. (Daniel Boulud's new restaurant), Sperone Westwater Gallery Building

Alan Shmaruk X11 Andrew Braver x13

The Manhattes Group LLC 54 Thompson Street 2nd Floor New York, NY 10012

212-334-4666

Basement

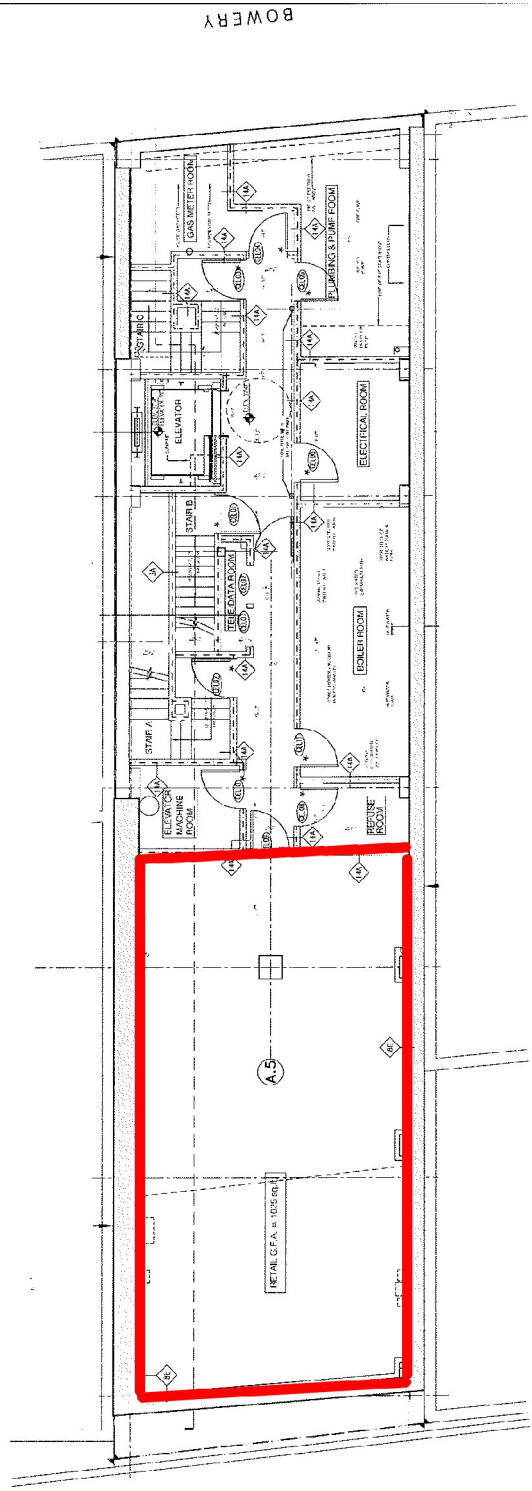

Ground Floor

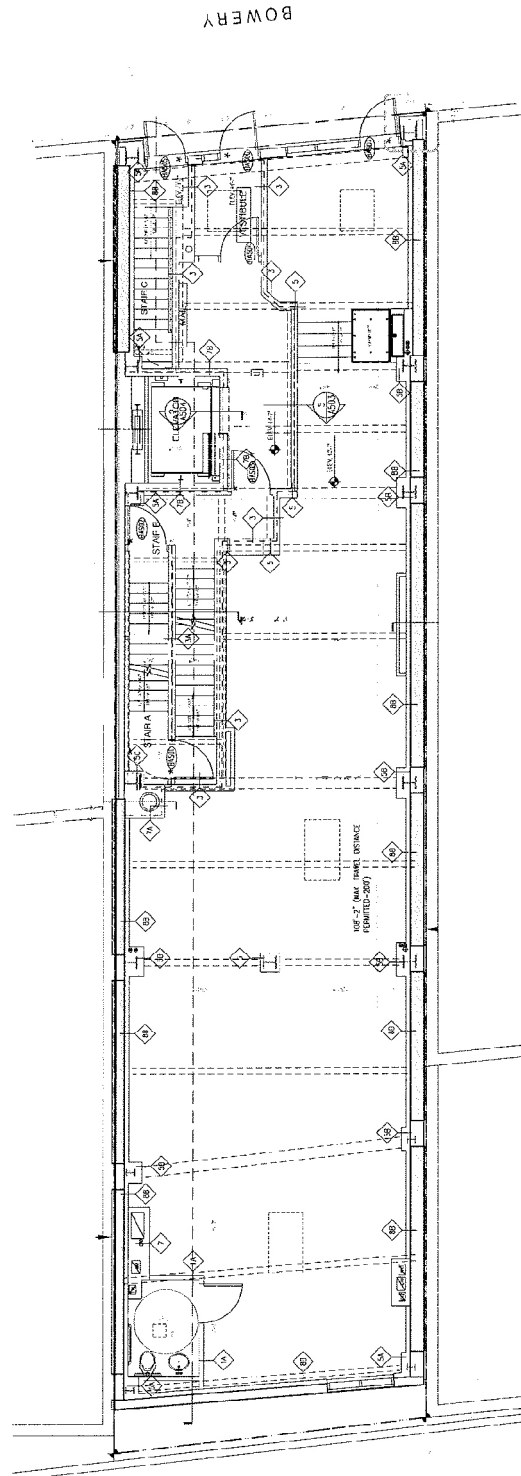

Alan Shmaruk X11 Andrew Braver x13

The Manhattes Group LLC 54 Thompson Street 2nd Floor New York, NY 10012

212-334-4666

Second Floor

BOWERY

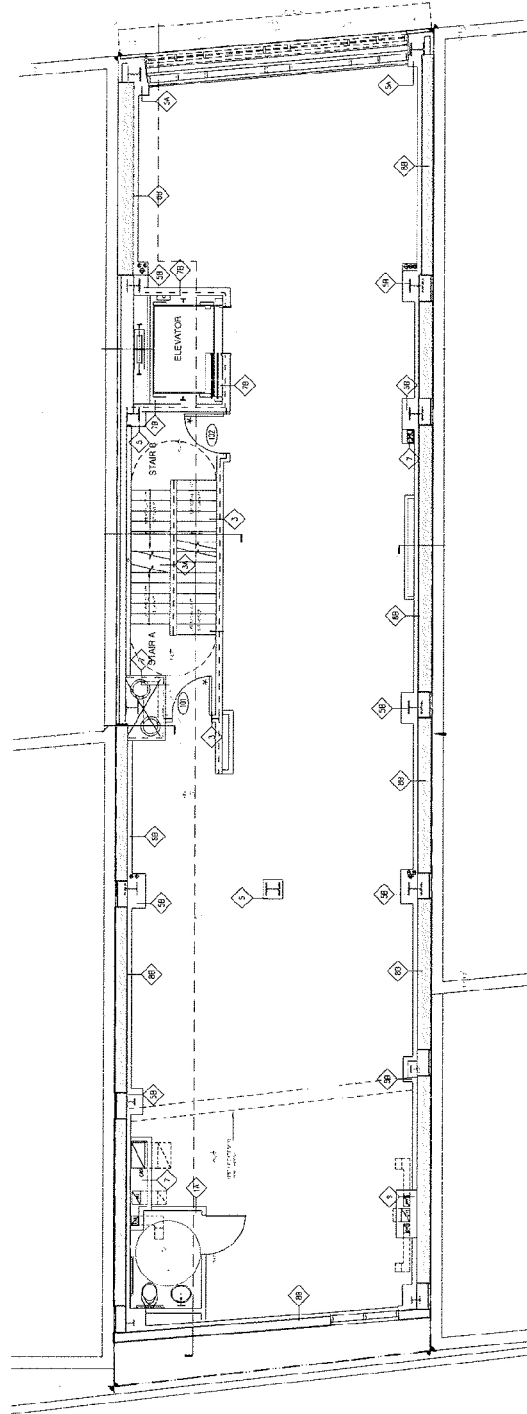

Alan Shmaruk X11 Andrew Braver x13

The Manhattes Group LLC 54 Thompson Street 2nd Floor New York, NY 10012

212-334-4666

Third Floor

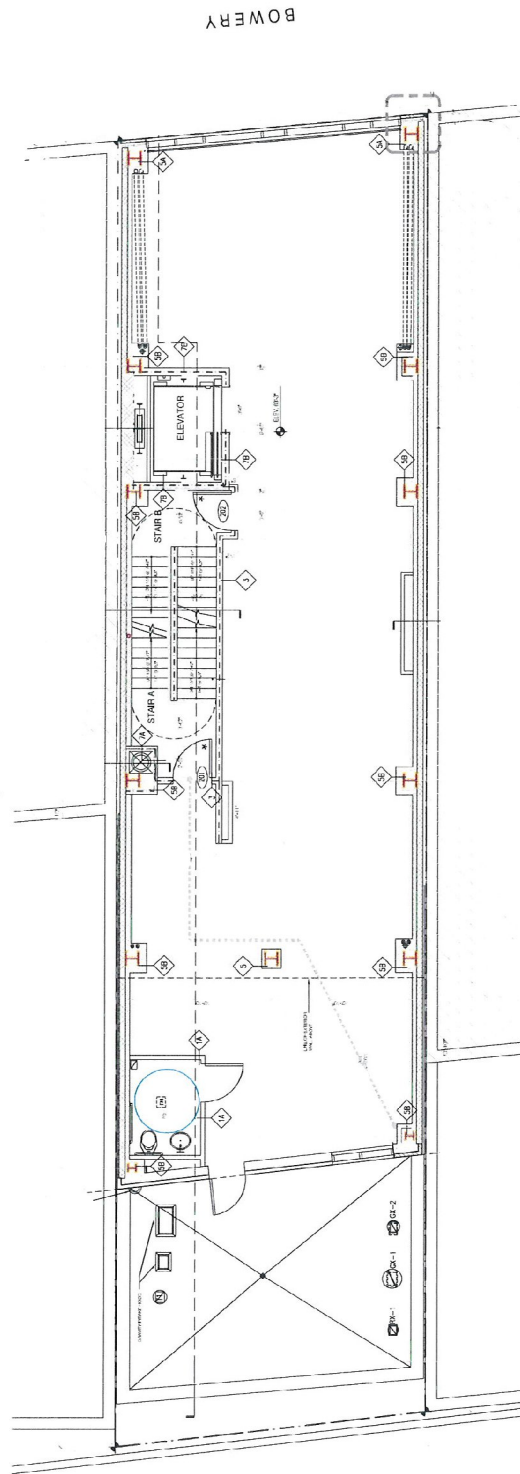

Alan Shmaruk X11 Andrew Braver x13

The Manhattes Group LLC 54 Thompson Street 2nd Floor New York, NY 10012

212-334-4666